

120R-101697 REV.: 6

REV.	DESCRIPTION	DATE	BY

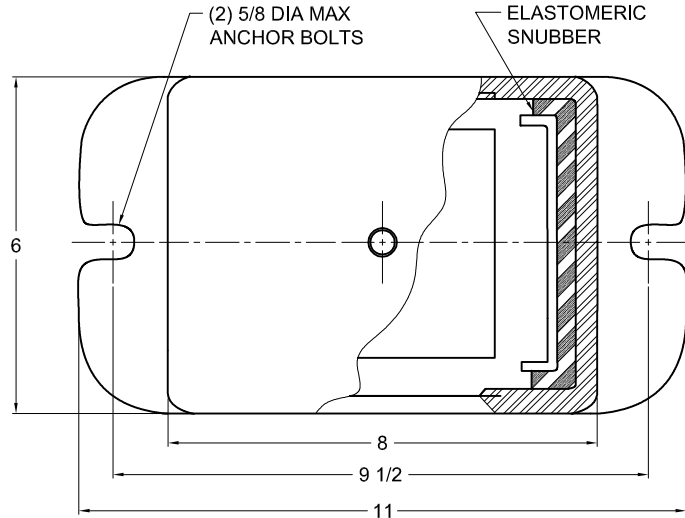

**TYPE C4ALP CAST ALUMINUM SPRING ISOLATORS
WITH INTERNAL ADJUSTMENT AND POSITIONING PIN**

MODEL	MAX LOAD (LBS)	DEFLECTION (IN)	SPRING RATE (LB/IN)	SPRING COLOR CODE
C4ALP-1D-340	340	1.35	252	LT PURPLE
C4ALP-1D-480	480	1.20	400	DK YELLOW
C4ALP-1D-700	700	1.17	600	DK BLUE
C4ALP-1D-1000	1000	1.40	716	YELLOW
C4ALP-1D-1360	1360	1.13	1200	RED
C4ALP-1D-2040	2040	1.02	2000	BLACK
C4ALP-1D-2700	2700	1.32	2052	DK PURPLE
C4ALP-1D-3600	3600	1.02	3524	DK GREEN
C4ALP-1D-4800	4800	0.90	5308	GRAY
C4ALP-1D-5440	5440	0.77	7032	WHITE
C4ALP-1D-7140N ¹	7140	0.88	8116	GRAY/RED

NOTES:

1. TWO NESTED SPRINGS YIELD THIS LOAD. THE COLOR CODE IS FOR OUTER SPRING/ INNER SPRING.

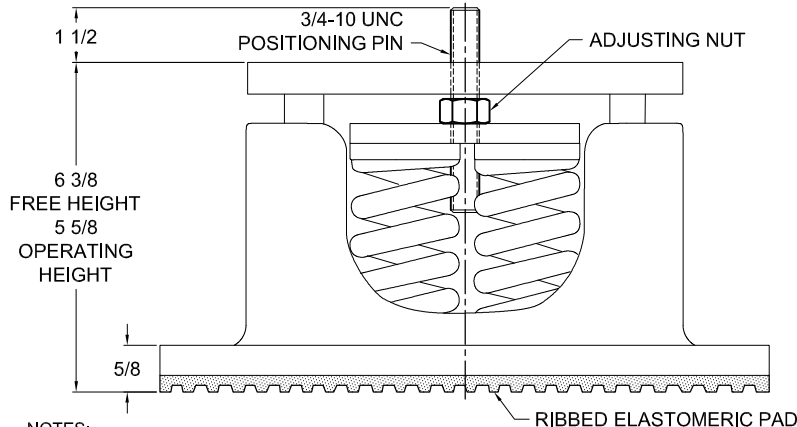

NOTES:

1. ALL DIMENSIONS ARE IN INCHES, INTERPRET PER ANSI Y14.
2. UNLESS OTHERWISE NOTED, DIMENSIONS FOR STYLE APPLY TO ALL OTHER STYLES.
3. FINISH: HOUSINGS-CAST ALUMINUM, SPRINGS-POWER COAT, HARDWARE- ZINC ELECTROPLATE.
4. REFER TO SHEET 2 OF 2 FOR INSTALLATION INSTRUCTIONS.
5. INNER SPRING (WHEN USED) NOT SHOWN.
6. ALL SPRINGS ARE DESIGNED WITH 50% OVER TRAVEL.
7. DETAILS NOT SHOWN ON OTHER VIEW FOR CLARITY.
8. RATED DEFLECTIONS ARE WITHIN 25% OF NOMINAL. HIGHER DEFLECTIONS ARE ALLOWED IF THEY MEET SPECIFICATIONS.

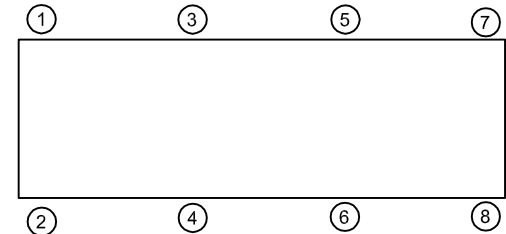

ISOLATOR SELECTIONS

LOC 1:	LOC 2:
LOC 3:	LOC 4:
LOC 5:	LOC 6:
LOC 7:	LOC 8:
CUSTOMER EQPT. TAG:	

NOTE: MATERIAL SHOWN IS FOR (1) SET.

OTHER MATERIALS, COMPOUNDS, OR FINISHES WITH EQUAL OR SUPERIOR PROPERTIES MAY BE SUBSTITUTED AS THEY BECOME AVAILABLE.

CERTIFIED FOR:

JOB NAME: _____
 CUSTOMER: _____
 CUSTOMER P.O.: _____
 SALES ORDER: _____

**MODEL C4ALP-1D 340-7140 LBS.
 ALUM. SPRING ISOLATORS SNUBBED WITH
 INTERNAL ADJUSTMENT AND
 POSITIONING PIN
 1 INCH DEFLECTION**



THE VMC GROUP
The Power of Together
 Bloomingdale, NJ 07403
 Houston, TX 77041

SCALE:

NONE

SHEET:



DRAWING NO.:

REVISION

120R-101697 REV.: 6

REV.	DESCRIPTION	DATE	BY

READ INSTRUCTIONS IN THEIR ENTIRETY BEFORE BEGINNING.

ALL VMC GROUP HOUSED ISOLATORS ARE SHIPPED ASSEMBLED AND IDENTIFIED BY SIZE (LOAD CARRYING CAPACITY) AND BY THE COLOR CODE ON THE SPRINGS. THE NORMAL INSTALLATION AND ADJUSTMENT OF THIS TYPE ISOLATOR IS AS FOLLOWS:

- LOCATE THE ISOLATORS IN THEIR PROPER POSITION UNDER THE EQUIPMENT. SEE SUBMITTAL DATA, INSTALLATION DRAWINGS, OR OTHER CORRESPONDENCE FOR CORRECT LOCATION OF ISOLATORS WHEN DIFFERENT CAPACITY ISOLATORS ARE USED FOR UNEQUAL LOAD DISTRIBUTION. ISOLATORS SHOULD BE SET ON A FLAT, LEVEL SURFACE AT THE SAME ELEVATION. SHIMS, IF REQUIRED, SHOULD BE FULL SIZE.
- BEFORE THE ISOLATORS ARE ADJUSTED, THE WEIGHT OF THE EQUIPMENT MAY CAUSE THE TOP PLATE TO COME TO REST ON THE HOUSING. THE ISOLATORS SHOULD BE ADJUSTED TO PROVIDE A MINIMUM CLEARANCE OF 1/4" BETWEEN THE TOP PLATE AND THE HOUSING.
- ONCE ISOLATORS ARE IN POSITION, PLACE BLOCKING ALONGSIDE ISOLATOR. BLOCKING HEIGHT SHOULD BE EQUIVALENT TO THE FREE HEIGHT OF THE ISOLATOR AND BE CAPABLE OF SUPPORTING WEIGHT.
- COMPRESS THE SPRINGS BY TURNING THE ADJUSTING NUT "A" CLOCKWISE. START AT ONE ISOLATOR AND MAKE FOUR TURNS ON THE ADJUSTING NUT "A", MOVE TO THE NEXT ISOLATOR AND MAKE FOUR TURNS, ETC., UNTIL ALL ISOLATORS HAVE BEEN ADJUSTED FOUR TURNS. REPEAT THIS PROCEDURE UNTIL A 1/4" CLEARANCE IS OBTAINED BETWEEN TOP PLATE AND HOUSING. RECOMMENDED MAXIMUM TORQUING OF ISOLATOR BASE ANCHORS TO 5 FT-# AFTER EQUIPMENT IS INSTALLED.
- CHECK THE LEVEL OF THE EQUIPMENT. THE EQUIPMENT MAY NOW BE LEVELED BY MAKING SMALL ADJUSTMENTS OF INDIVIDUAL ISOLATORS AT THE HIGH AND LOW POINTS.
- AFTER THE EQUIPMENT IS LEVEL, VISUALLY CHECK EACH ISOLATOR TO MAKE SURE SPRING COILS ARE NOT CLOSED SOLID AND THERE IS SUFFICIENT CLEARANCE BETWEEN TOP PLATE AND HOUSING.

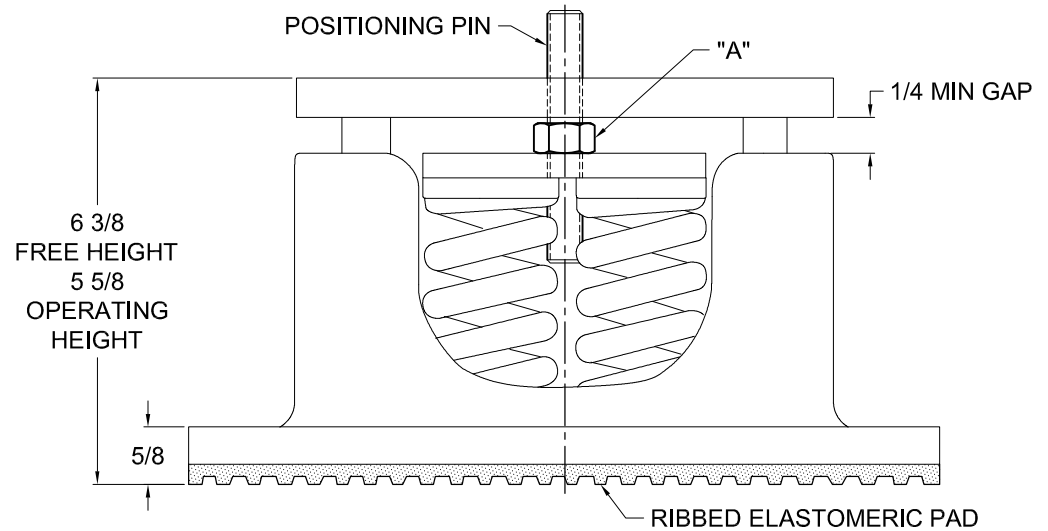

NOTES:

- ALTHOUGH PROVISIONS HAVE BEEN MADE FOR ANCHOR BOLTS, THE NON-SKID ELASTOMERIC PAD ON THE BOTTOM OF THE ISOLATOR IS USUALLY SUFFICIENT TO PREVENT "WALKING" OF EQUIPMENT, AND NO BOLTING IS REQUIRED.
- IF ISOLATOR MUST BE BOLTED TO SUPPORTING STRUCTURE, BOLTS SHOULD BE HAND-TIGHT. DO NOT OVER-TIGHTEN.

OTHER MATERIALS, COMPOUNDS, OR FINISHES WITH EQUAL OR SUPERIOR PROPERTIES MAY BE SUBSTITUTED AS THEY BECOME AVAILABLE.

CERTIFIED FOR:

JOB NAME: _____
 CUSTOMER: _____
 CUSTOMER P.O.: _____
 SALES ORDER: _____

**MODEL C4ALP-1D 340-7140 LBS.
 ALUM. SPRING ISOLATORS SNUBBED WITH
 INTERNAL ADJUSTMENT AND
 POSITIONING PIN
 1 INCH DEFLECTION**



THE VMC GROUP
The Power of Together
 Bloomingdale, NJ 07403
 Houston, TX 77041

SCALE: NONE
 SHEET: _____



DRAWING NO.: _____ REVISION _____